

592 SMART Interval Import Aggregation

<p>The following statement will be true for the composition of the 592 Market Message</p>
<p>Invalid Combinations should not be populated in the message, however if there are no MPRNs registered for a valid combination then a count of zero should be populated in the message</p>
<p>The implication of this statement is that where the DLF is LV:</p>
<p>the count of MPRNs , Load profile and DLF will always be included for each of the Load Profiles 01-12 in the segment Additional Aggregation Information</p>
<p>And where the Count of MPRNs is zero, none of the lower level segments will be populated viz no Additional Aggregated Consumption, no Additional Aggregation Data segments for that Load Profile/DLF combination</p>
<p>where the DLF is not LV:</p>
<p>there should be none of the segments : Additional Aggregation Information , Additional Aggregated Consumption, Additional Aggregation Data segments</p>

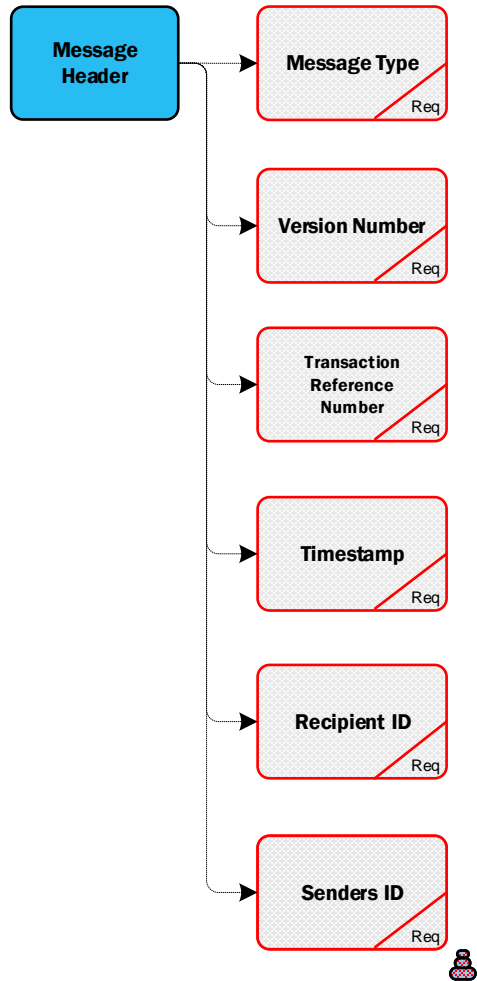

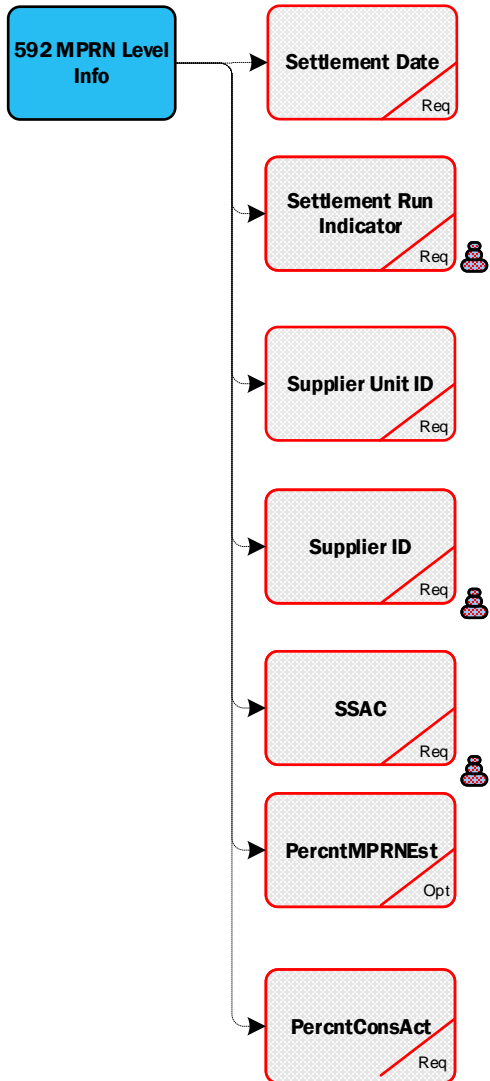

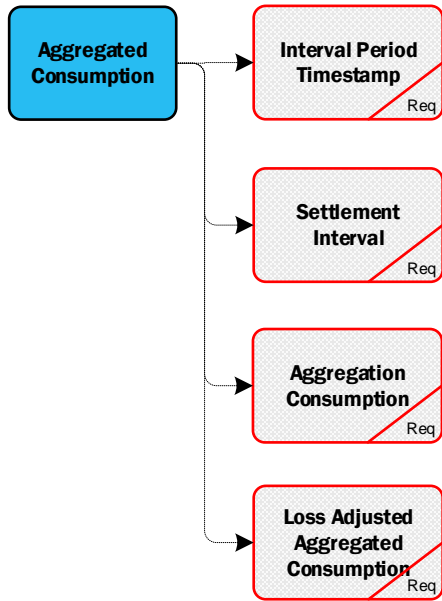

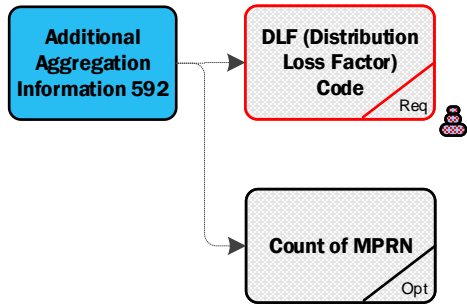

**Senders
ID**

**Click Here for Latest
Senders ID
List**

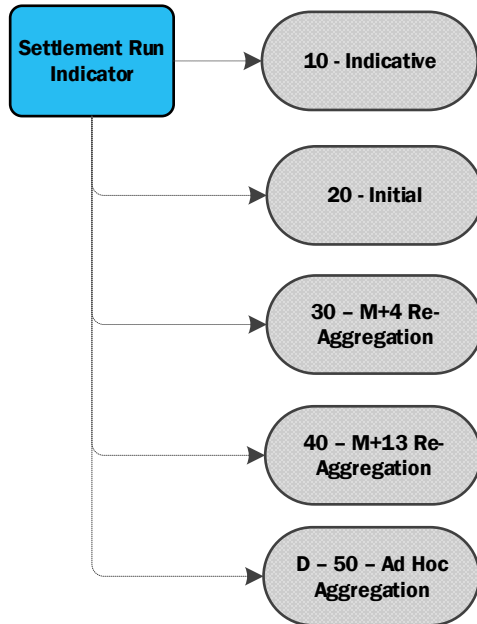

**Supplier
ID**

**Click Here for Latest
Supplier ID
List**

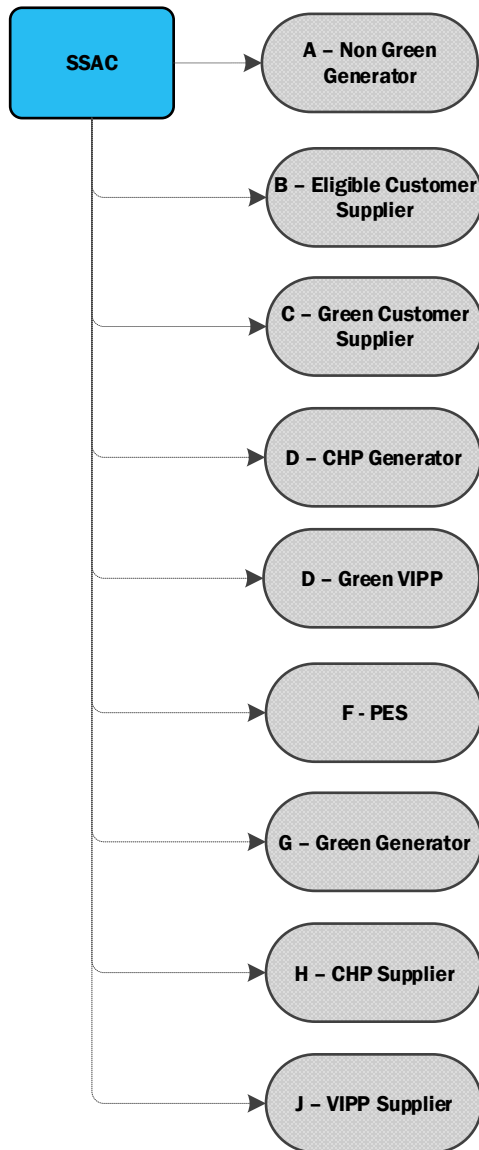

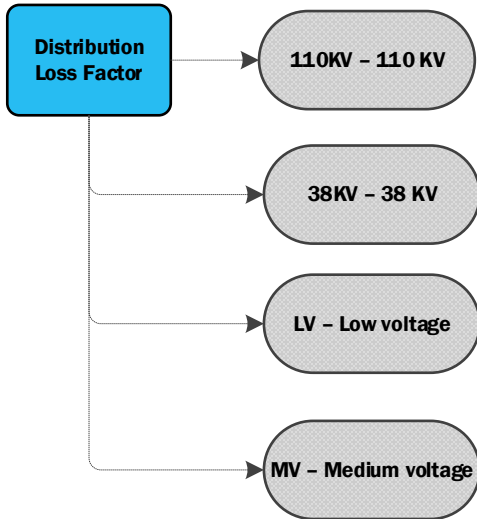

592 SMART Interval Import Aggregation

Version Which Implemented	Source of Change	Description of Change
13.0	V13.00 Smart changes	New Market Message for Smart